

Equipment sheet fireplace Kalius RLU 291.12-P Art. Nr. 0429112010000

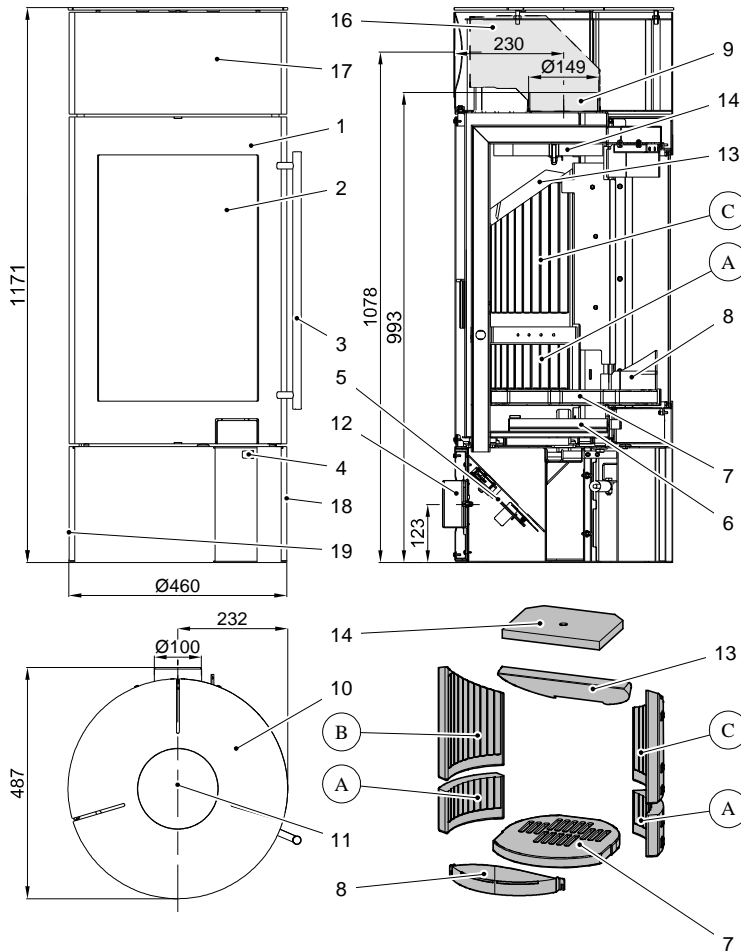

Suitable fuels:

The following materials are approved for burning in your fireplace (refer also to chapter 5.1.):
Dry, natural wood, wood briquettes according to DIN 51731;

Fuel quantities, setting of combustion air damper, operation:

See chapters 5.4, 5.5 and 5.6 in the Operating Instructions and table below.

Article nr.	Stone No.	Dimension
0428712005501	A	211x130x40
0428712005504	B	338x211x40
0428712005505	C	338x211x40

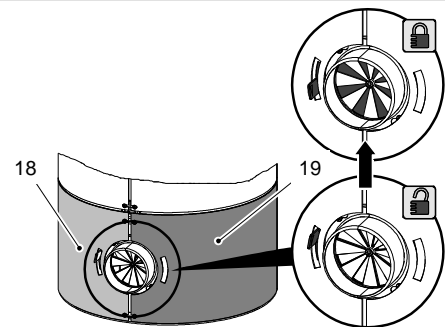

Fuels	Maximum fuel quantity	Primary air damper (4) (Air flow through the grating)	Secondary air damper (5) heating
Wood billets, wood briquettes	2 billets (ca. 1,0 – 1,5 kg) or 1 wood briquette (1,5 kg)	For 10 minutes: Open, then closed	Automatic

Spare parts no.	Item	Designation	Spare parts no.	Item	Designation
0428612005300	1	Fire chamber door - black	0421817006001	11	Insert plate - black
0428612005310	2	Door glas 540x351	0088500050008	12	Outside air - pipe fitting Ø 100
0429112005375	3	Door handle	0428712005507	13	Lower draft deflection plate 380x192x30
0428612015012	4	Primary air damper	0429112005508	14	Upper draft deflection plate 290x230x25
0089900470005	5	Secondary air damper - automatic	0332015007065	16	Elbows 90° (Ø 150) not included
0428612005600	6	Ash pan - black	0428612005065	17	Hood
0428612005520	7	Base support framework 352x330x30	0428612015036	18	Sheet rear right
0428612005700	8	Upright grating - black	0428612015039	19	Sheet rear left
-	9	Smoke pipe spigot	0041012120005	-	Seal door 12 mm
0428612005800	10	Cover plate - black	0040225030005	-	Seal glass 25x3mm

Technical data:		Kalius RLU 291.12-P	
Height	1171 mm	Flue gas temperature on the spigot of the heat generator	326 °C
Width	Ø 460 mm	Minimum delivery pressure	12 Pa
Depth without handles	481 mm	Minimum delivery pressure with 0.8 times rated thermal capacity	10 Pa
Weight	104 kg	Flue mass flow	2,8 g/s
Pipe spigot	150 mm	Fuel	Wood
Rated heating capacity	5 kW	CO2	13,6 %
Thermal output range	2,6 – 5,4 kW	Efficiency	87 %
Inspection no :EN 13240 RRF 40 13 3211-1 / BZ 13 3211-1			